



ZHEJIANG FUJICN Elevator CO.,LTD

Elevator Electrical Diagram

Monarch NICE3000+

2019. 10

Note: 37KW above, the required external braking unit details see below

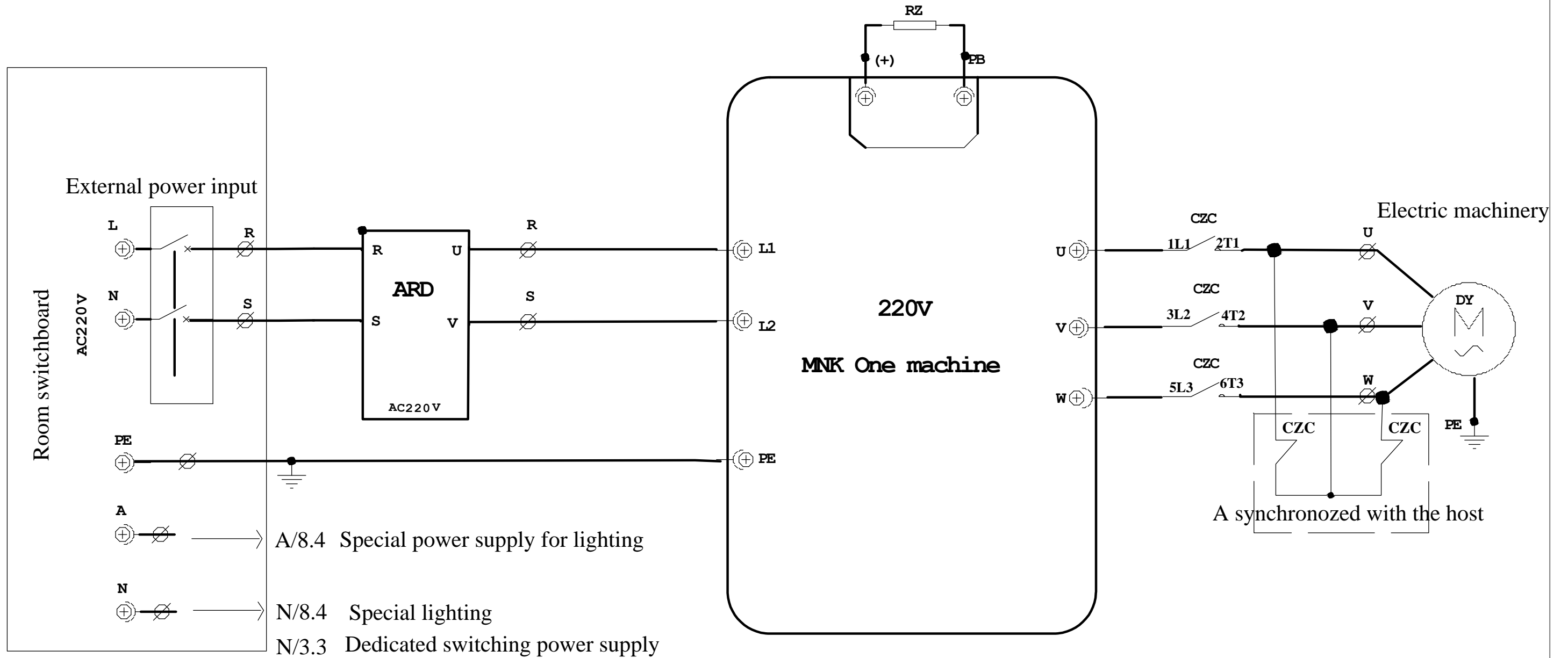

Let F8-09 emergency running speed when using the emergency source of electrical power, F8-10=1 UPS power supply operation

Let F5-20=27 UPS normally open input

- JP-1-1: 24V+ Input
- JP-1-2: X20UPS Effective signal
- JP-1-3: Short sequence A113
- JP-1-4: Short sequence A119

JP-1 Plug arrangement

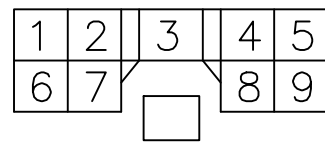

The main driving parts	BSJ
	1/20

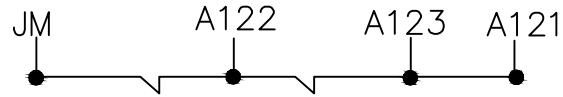
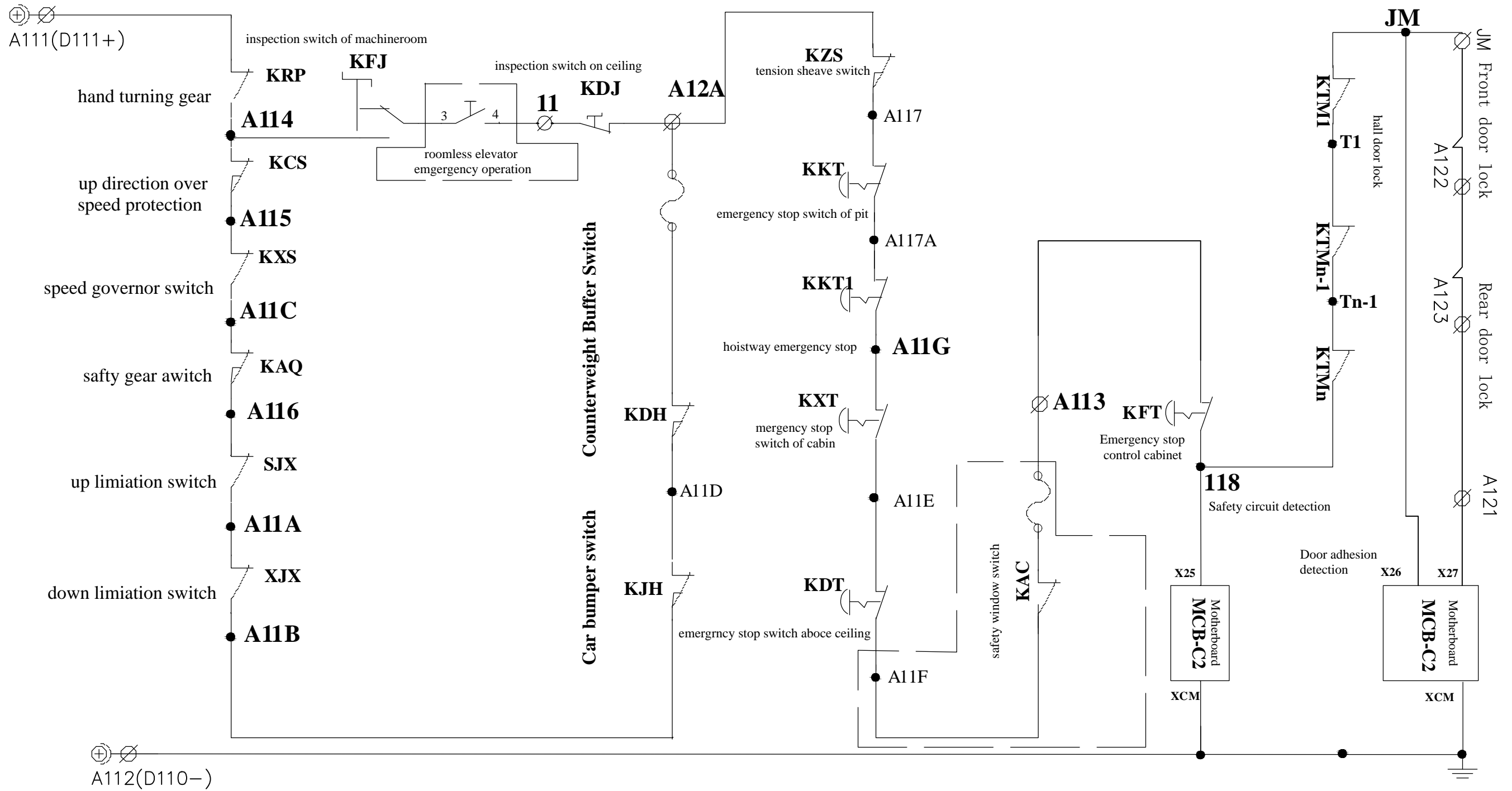

Note: when there is no rear car door, A122 and A123 are ignored

safety and door lock circuit (Induction motor)	BSJ
	2/20

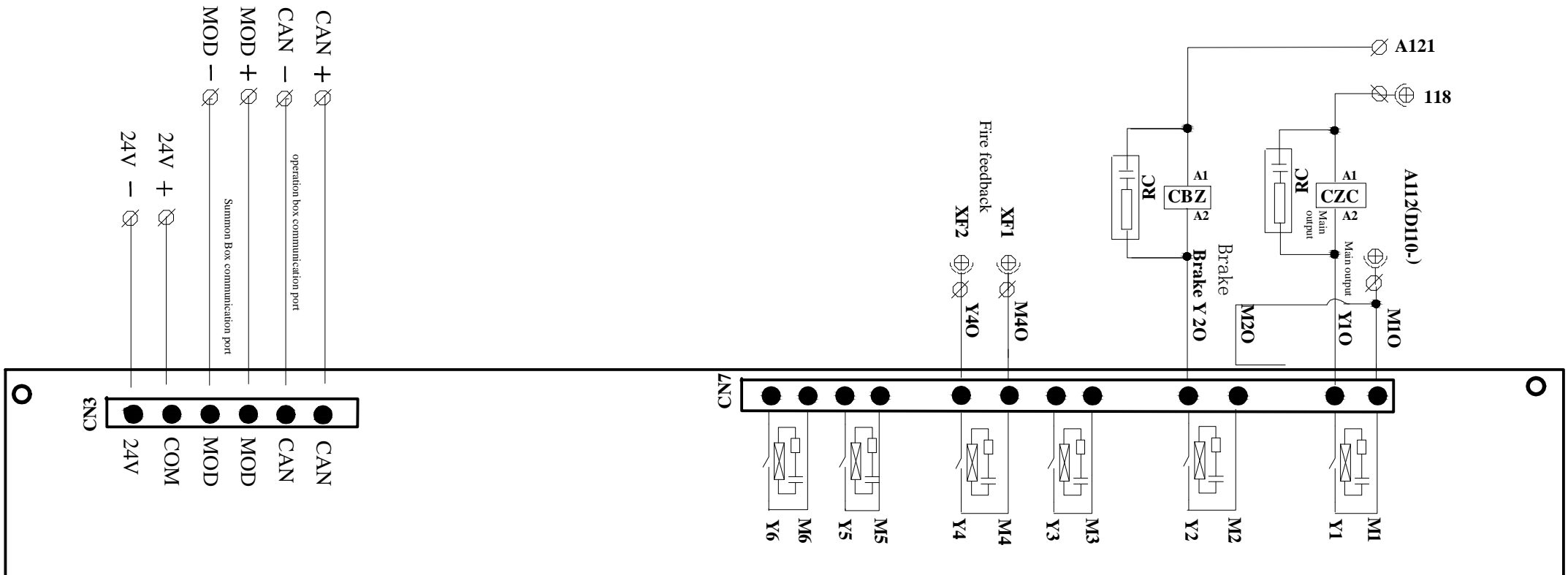

MCTC-MCB-C2 Main control board

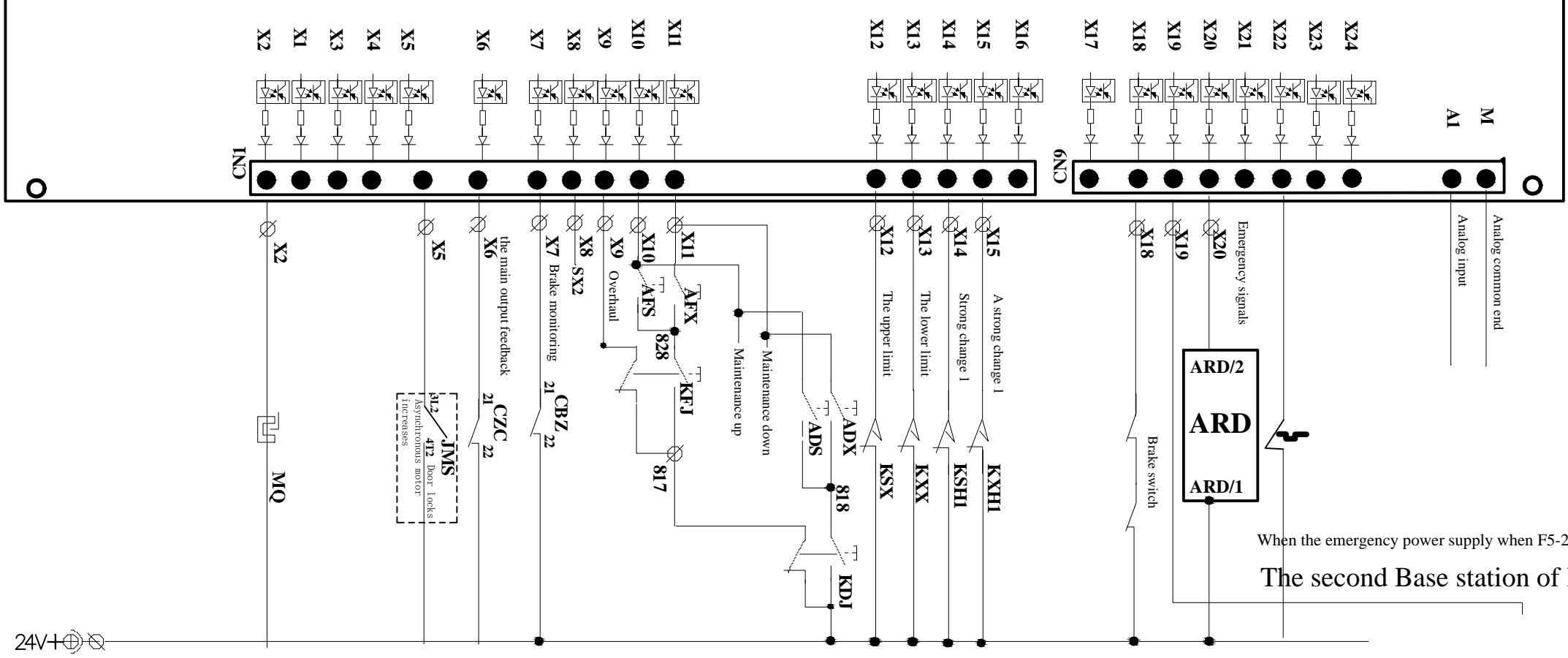

This line from the ladder for Parallel 24VG

When the emergency power supply when F5-20 is set to 27, F8-10=1
The second Base station of Firefighting F5-19=72 F8-12=2

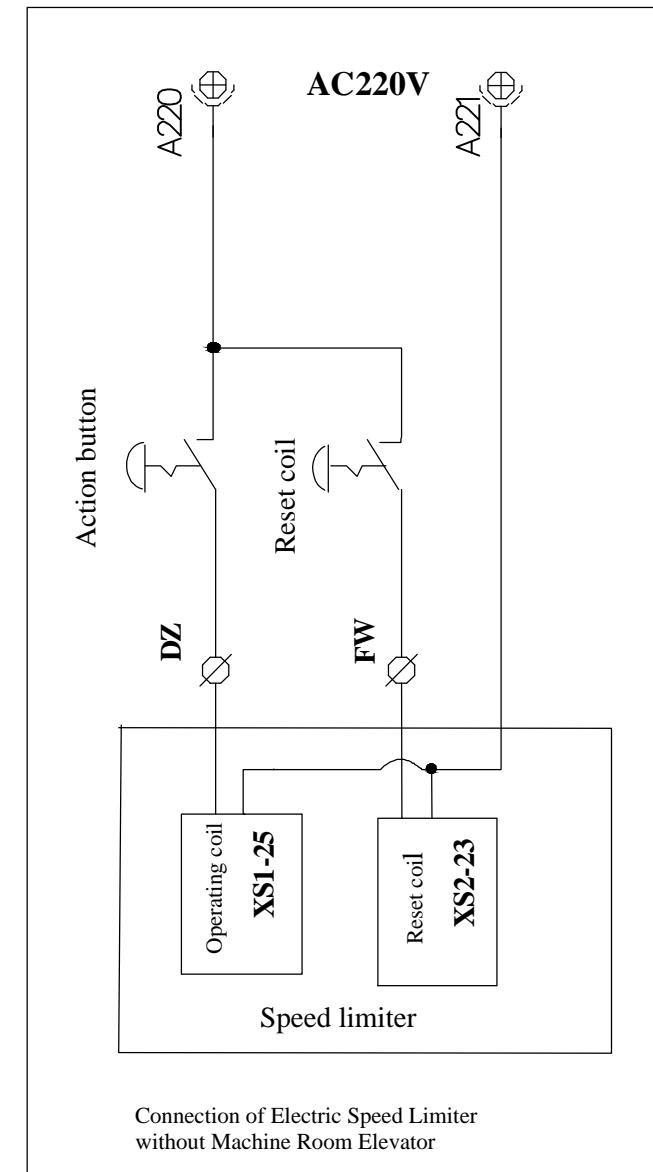
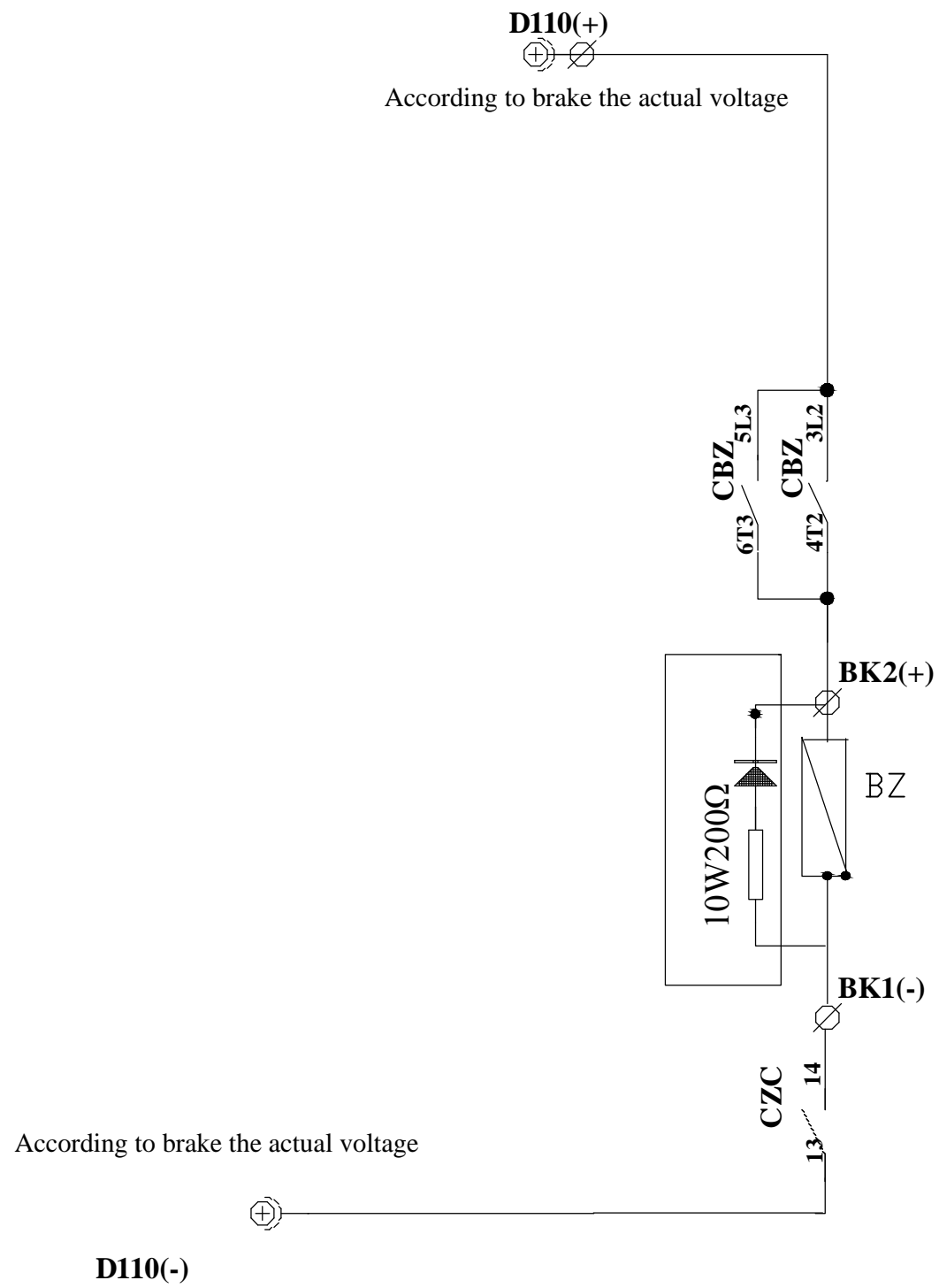

Brake control	BSJ
	4/20

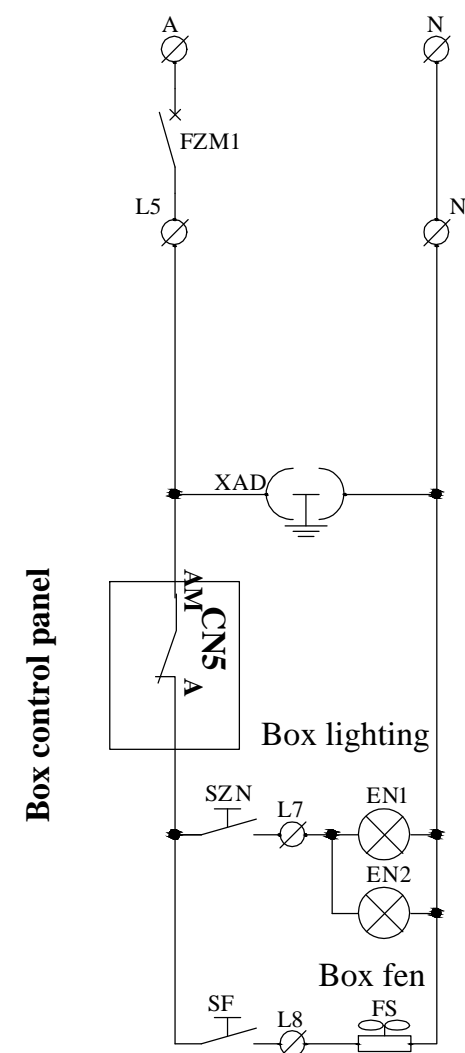
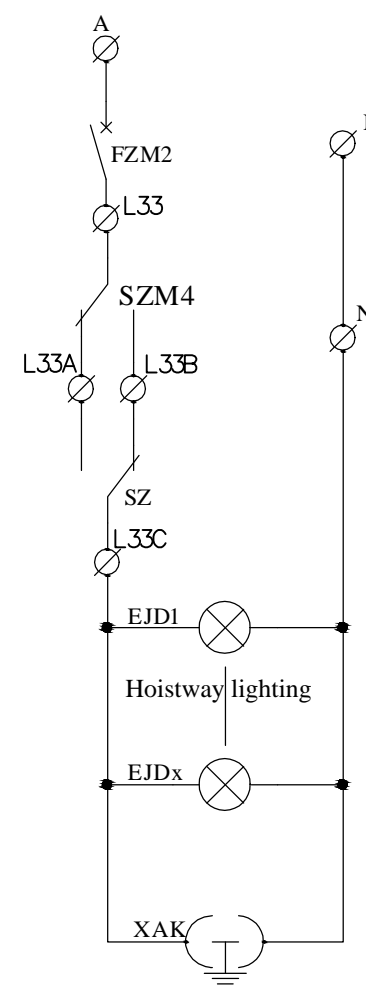
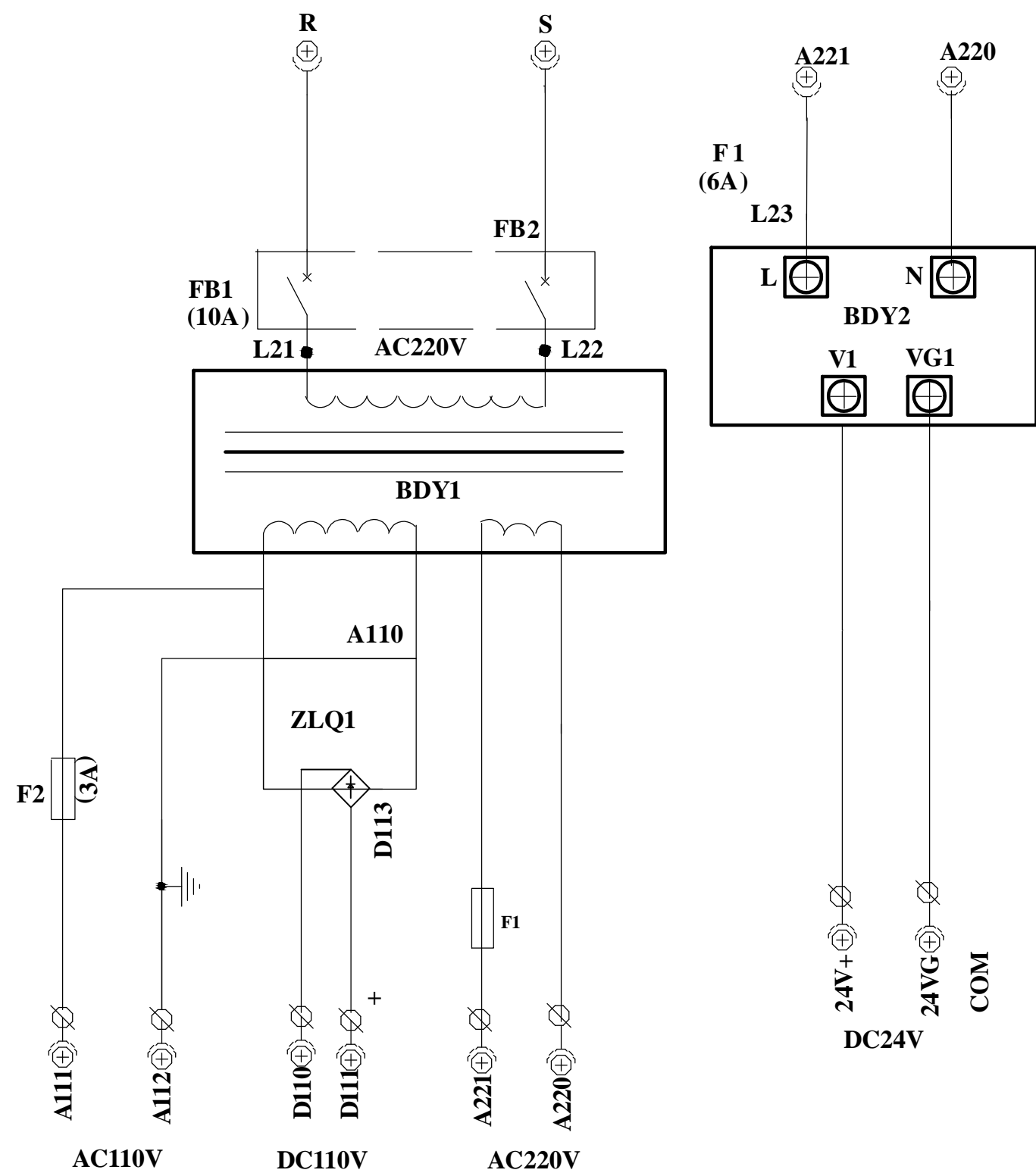

The power supply part	BSJ
	5/20

Electric cabinet plug-in cersion

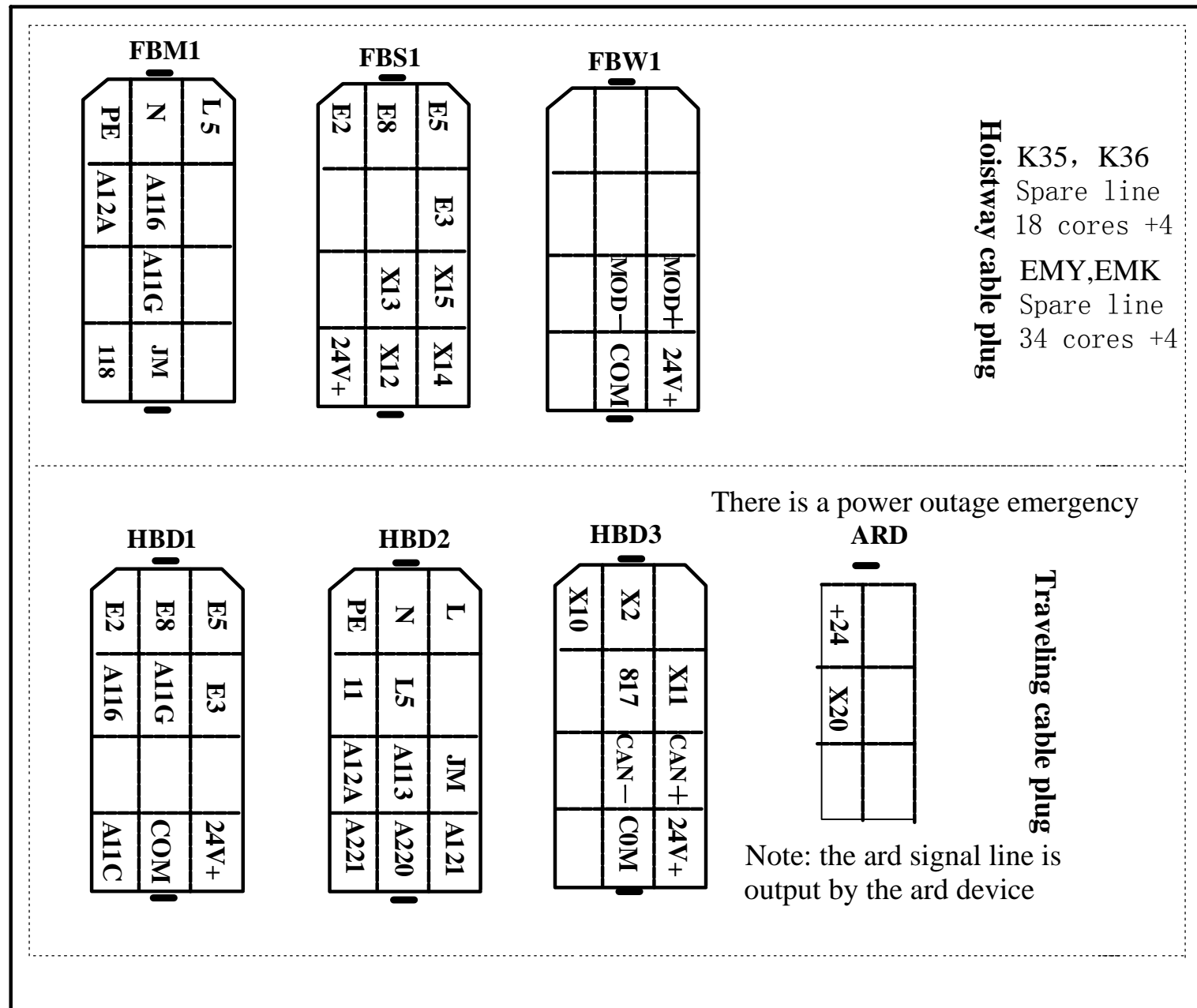

HB Twelve pin female port

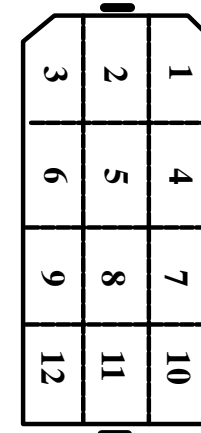

PS. Insert the same line should be short
FBW1 is well outbound communication
plug-in Computer room safety switch
terminal row

- A11C/A115 The governor switch
- A115/A114 Pick up overspeed switch
- A11C/A114 Then the force plate wheel switch

ARD

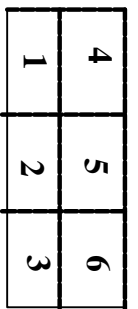

Terminal blocks

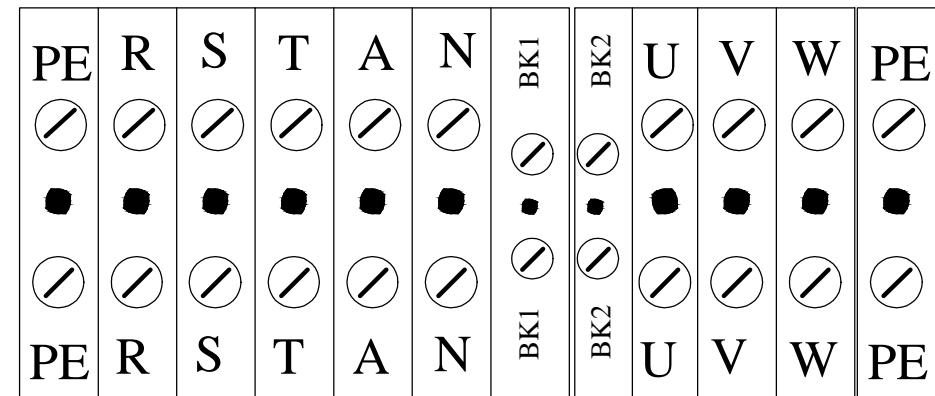

A short terminal line

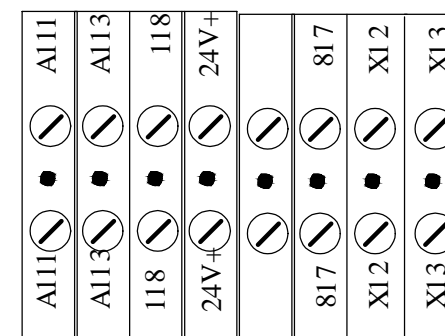

Computer room safety switch terminal blocks

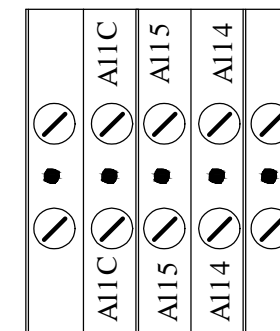

Dialogue dialogue connection

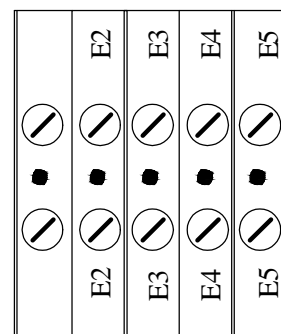

Note: X1: upper Flat layer
FL1: upper Flat layer again
FL2: Lower Flat layer again
X3: Lower Flat layer

Installation order from top to bottom:
The top sensor
Second sensor
Third sensor
The bottom of the sensor

Electric control cabinet plug-in

BSJ

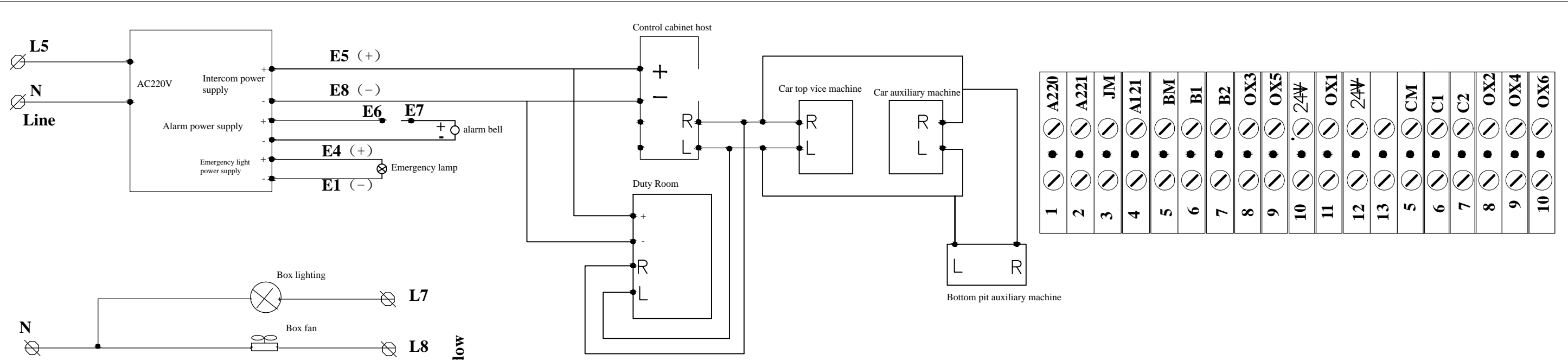

1	○	A220
2	●	A221
3	○	JM
4	○	A121
5	●	BM
6	○	B1
7	●	B2
8	○	OX3
9	○	OX5
10	○	24V
11	●	OX1
12	○	24V
13	○	
5	○	CM
6	○	C1
7	○	C2
8	○	OX2
9	○	OX4
10	○	OX6

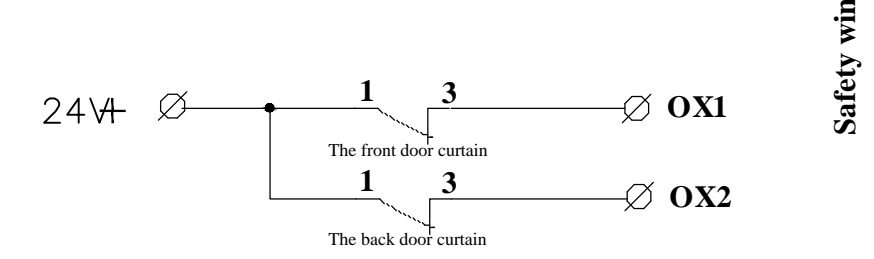

Safety window

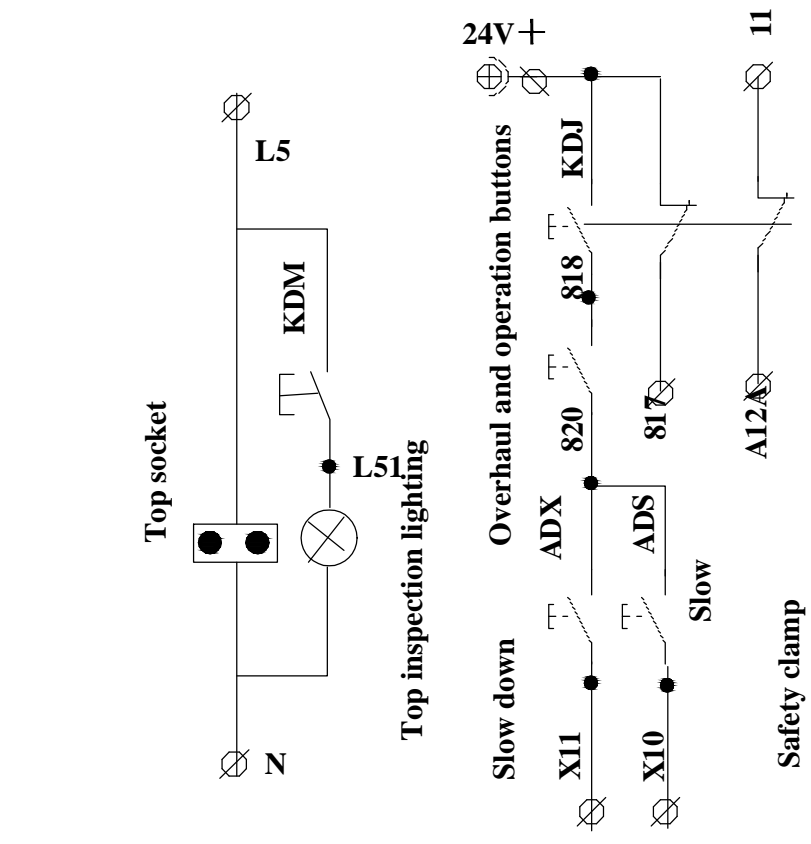

Top inspection lighting

Overhaul and operation buttons

Slow down

Slow

Safety clamp

Car emergency stop

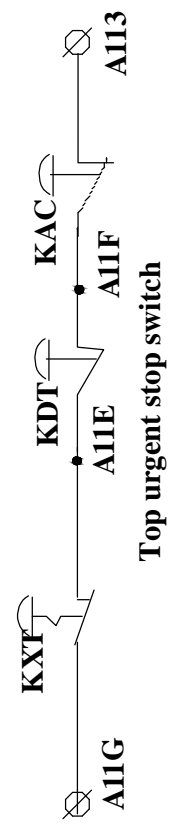

Top urgent stop switch

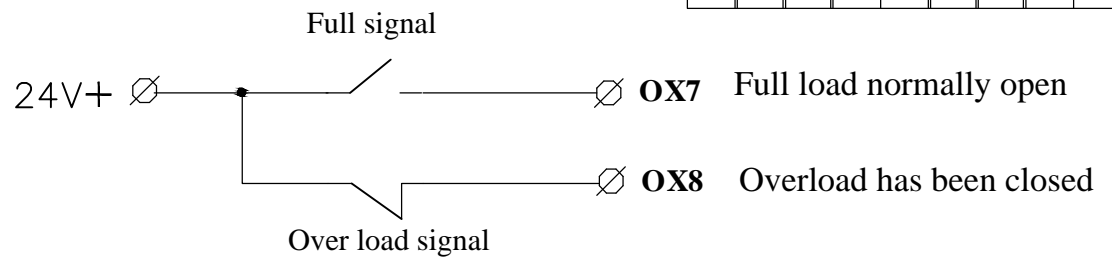

The top panel

1	○	24V+
2	○	COM
3	○	CAN+
4	○	CAN-
5	○	OX1
6	○	OX2
7	○	OX3
8	○	OX4
9	○	OX5
10	○	OX6
11	○	OX7
12	○	OX8

1	○	A11G
2	○	A11E
3	○	L5
4	○	L7
5	○	L8
6	○	E1
7	○	E2
8	○	E3
9	○	E4
10	○	E6
11	○	E7
12	○	PE

1	○	BM
2	○	B1
3	○	B2
4	○	CM
5	○	C1
6	○	C2
7	○	DM
8	○	D1
9	○	D2
10	○	PE

NOTE: overload device is mounted at the bottom of the elevator car, the installation of access OX8

Top inspection box	BSJ
	7/20

Traveling cable

HBD1

③	②	①
E2(R)	E8(-)	E5(+)
⑥	A116	A11G E3(L) ④
⑨	⑧	⑦
A11C	COM	+24V
⑫	⑪	⑩

HBD2

PE	N	L
11	L5	
A12A	A113	JM
A221	A220	A121

HBD3

X10	X2	
	817	X11
	CAN-	CAN+
	COM	+24V

QGM(Front door light screen)

①	A220	+24V	④
②	A221	OX1	⑤
③	PE		⑥

HGM(Rear door light curtain)

A220	+24V
A221	OX2
PE	

Note: when there is no back door, No light curtain at the back door

QMJ(Front door line)

PE	A221	A220
B2	B1	BM
OX5	OX3	+24V
	JM	A121

HMJ(Back door line)

Connect when there is a back door; do not connect when there is no back door

PE	A221	A220
C2	C1	CM
OX6	OX4	+24V
	A123	A122

C1(Connecting line to control panel)

L8	L7	L6
	A11E	A11G
E4(+)	E3(L)	E2(R)
E7	E6	E1(-)

Line

Five party call 220V

L5
N
PE

DJ

Car top intercom
Emergency light alarm

E2(R)	E8 -	E5(+)
E1(-)	E4 +	E3(L)
	E7	E6

Car roof branch and control box

MQLevel switch

+24V
COM
X2

AQQSafety gear switch

A11C
A116
PE

CZ

+24V
X8

overload switch

MZ

+24V
X7

Full load switch

To display in car XSQ

+24V	①
COM	②
MOD+	③
MOD-	④
	⑤

PZ(Arrival bell)

+24V
COM
D1、2

light

L7
N
PE

FAN

L8
N
PE

BSJ

Note:If the station clock,regardless of the up/down,make short D1/D2

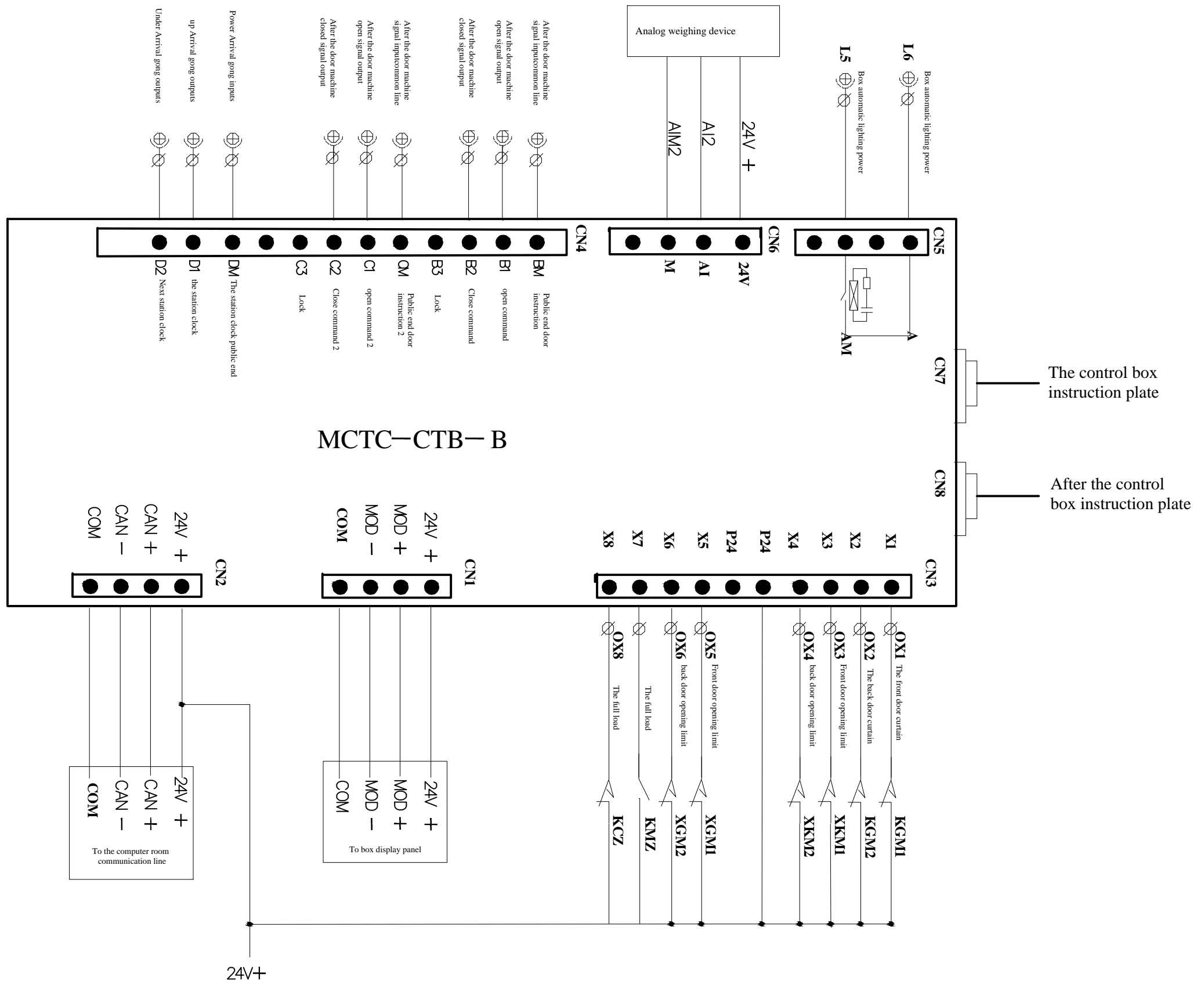

Auxiliary machine hoistway

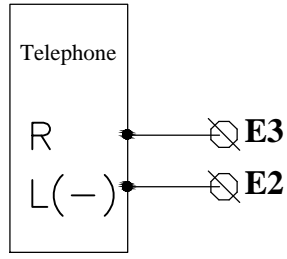

Socket on car top

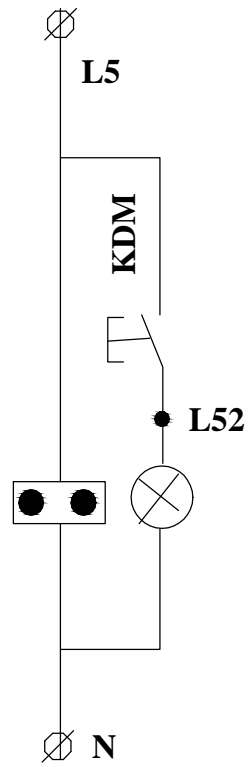

Inpection light power on car top

Car buffer switch Counterweight buffer switch

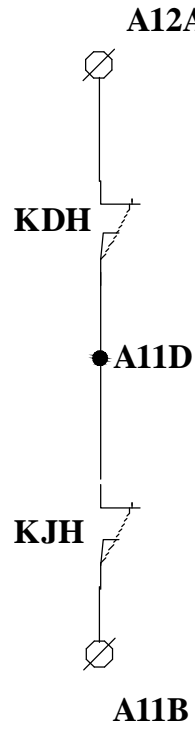

Hoistway emergency stop switch

Pi stop switch

Governor Tensioner switch



Hoistway emergency stop switch box wiring

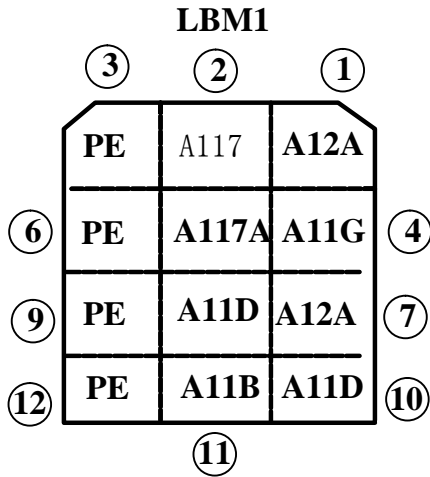
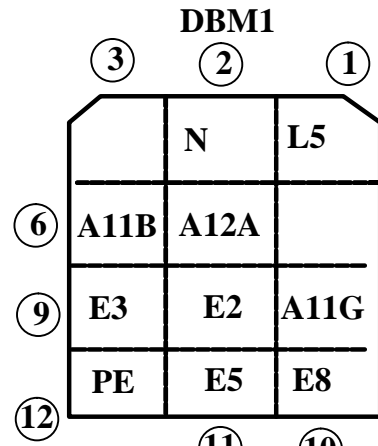
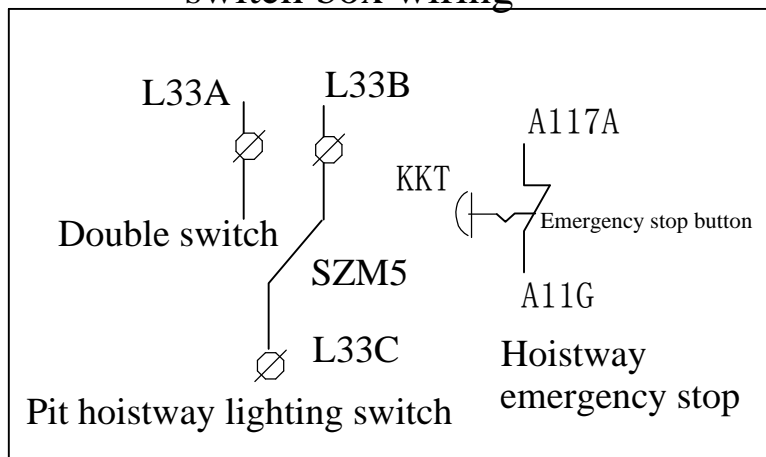

Pit bundle R2

Plug-needle NO	Drawing Symbol	Cable NO.	Function Descripyion
DBM1-1	L5	1	220V lighting
DBM1-2	N	2	
DBM1-3	K35	3	safe loop
DBM1-4	K36	4	
DBM1-5	A12A	5	
DBM1-6	A11 B	6	Five-party call
DBM1-7	A11 G	21	
DBM1-8	E2	17	
DBM1-9	E3	18	
DBM1-10	E8	19	Ground wire
DBM1-11	E5	16	
DBM1-12	PE	20	

Plug-needle NO	Drawing Symbol	Cable NO.	Function Descripyion
LBM1-1	A12A	1	Pit Tensioner switch
LBM1-2	A11 7	2	
LBM1-3	PE	3	

Plug-needle NO	Drawing Symbol	Cable NO.	Function Descripyion
LBM1--4	A11 G	1	Hoistway emergency stop switch
LBM1--5	A117A	2	
LBM1--6	PE	3	

Plug-needle NO	Drawing Symbol	Cable NO.	Function Descripyion
LBM1--7	A12A	1	Buffer switch
LBM1--8	A11 D	2	
LBM1--9	PE	3	

Plug-needle NO	Drawing Symbol	Cable NO.	Function Descripyion
LBM1--10	A11 D	1	Buffer switch
LBM1--11	A11 B	2	
LBM1--12	PE	3	

Non-hydraulic buffer, do not wiring, in the repair box to do short-circuit connector

Maintenance pit box

BSJ

10/20

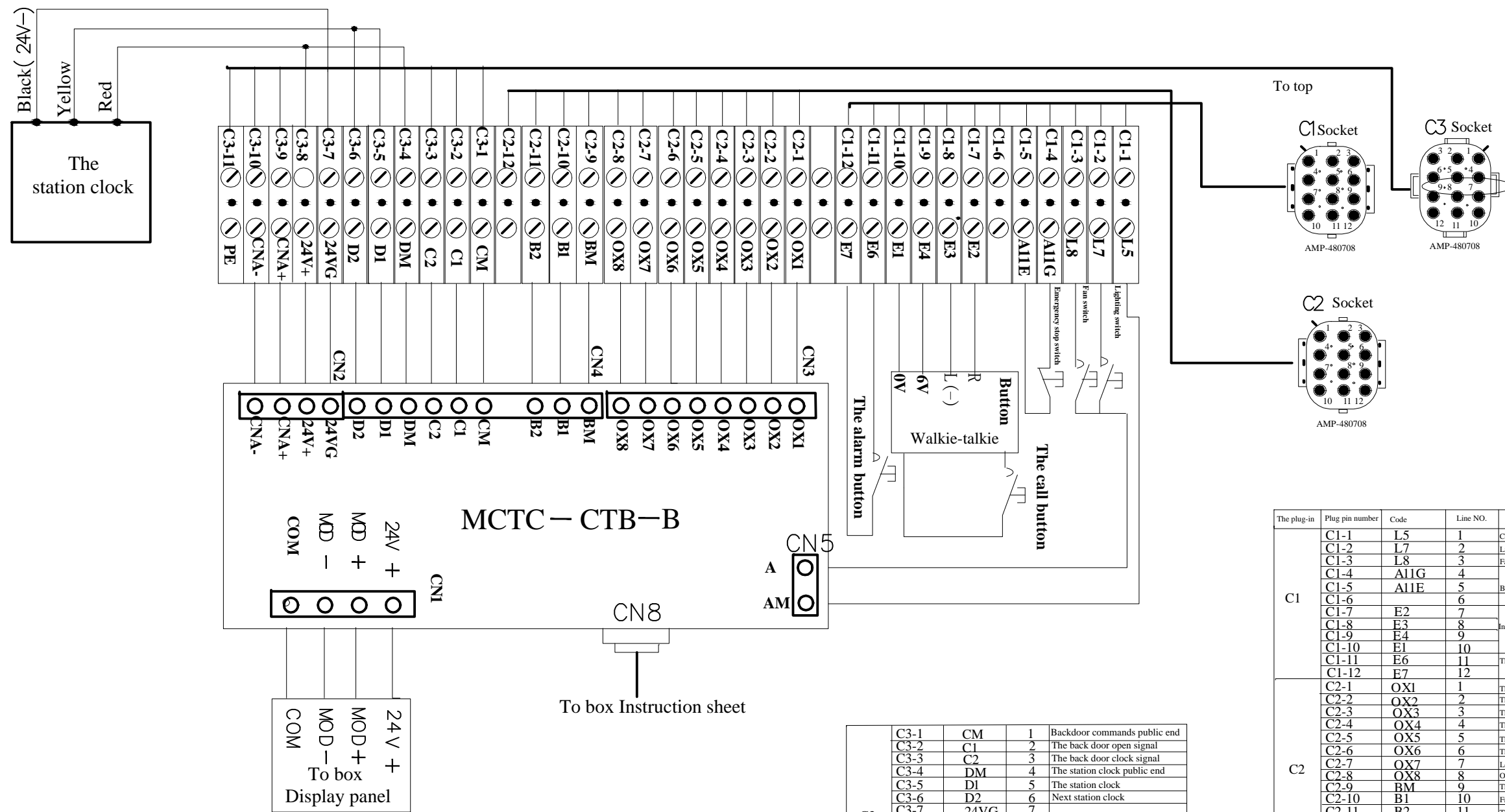

Code	Line NO.	Function description	
C3-1	CM	1	Backdoor commands public end
C3-2	C1	2	The back door open signal
C3-3	C2	3	The back door clock signal
C3-4	DM	4	The station clock public end
C3-5	D1	5	The station clock
C3-6	D2	6	Next station clock
C3-7	24VG	7	Load switch
C3-8	24V+	8	Overload switch
C3-9	CAN+	9	The front end of the instruction of public
C3-10	CAN-	10	Serial communication signal
C3-11	PE	11	
C3-12			

The plug-in	Plug pin number	Code	Line NO.	Function description
C1	C1-1	L5	1	Common line
	C1-2	L7	2	Lighting
	C1-3	L8	3	Fan
	C1-4	AIIG	4	
	C1-5	A1IE	5	Box Emergency stop
	C1-6		6	
	C1-7	E2	7	
	C1-8	E3	8	Intercom system
	C1-9	E4	9	
	C1-10	E1	10	
	C1-11	E6	11	The alarm switch
	C1-12	E7	12	
C2	C2-1	OX1	1	The front door curtain
	C2-2	OX2	2	The back door curtain
	C2-3	OX3	3	The front door open in place
	C2-4	OX4	4	The back door in place
	C2-5	OX5	5	The front door closing in place
	C2-6	OX6	6	The front door closing in place
	C2-7	OX7	7	
	C2-8	OX8	8	
	C2-9	BM	9	The front end of the instruction of public
	C2-10	B1	10	Front door open signal
	C2-11	B2	11	The front door close signal
	C2-12			

Well fixed communication cable 4 core twisted pair shielded RVV4*0.75 P

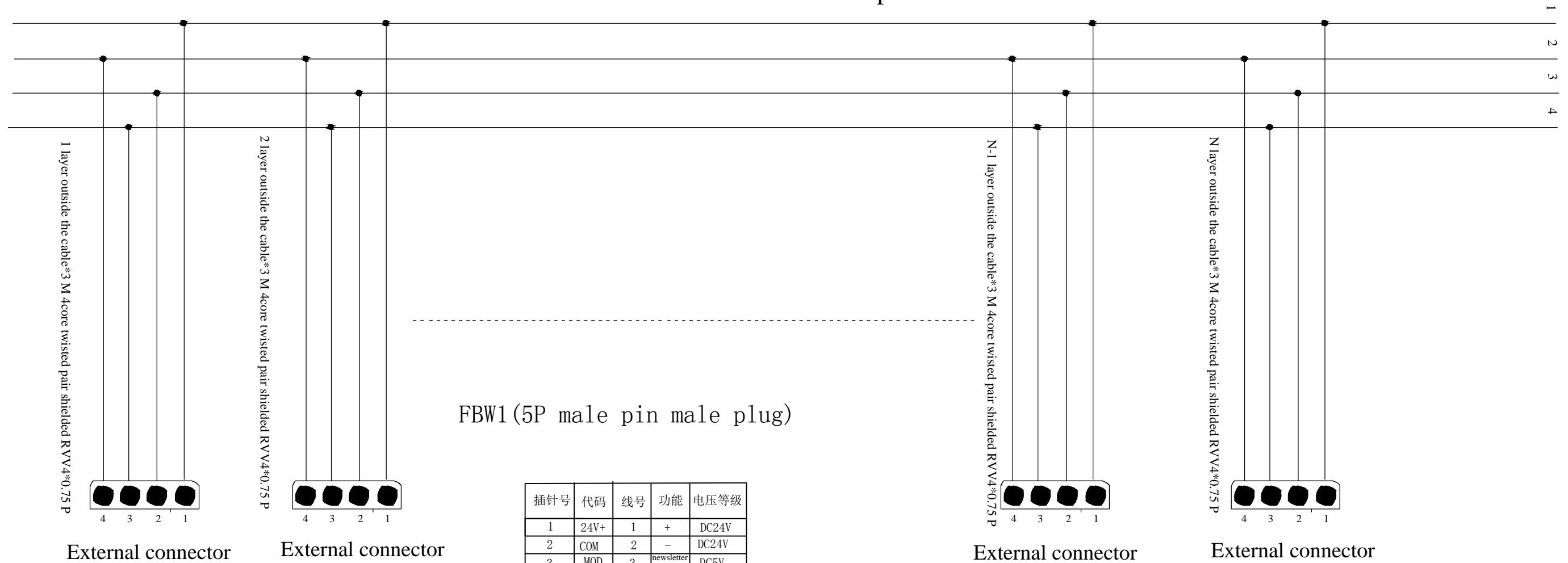

FBW1 (5P male pin male plug)

插针号	代码	线号	功能	电压等级
1	24V+	1	+	DC24V
2	COM	2	-	DC24V
3	MOD	3	newsletter 1	DC5V
4	MOD	4	newsletter 2	DC5V
5	PE	5	Shielded cable	PE

FBW1 Plug

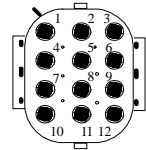

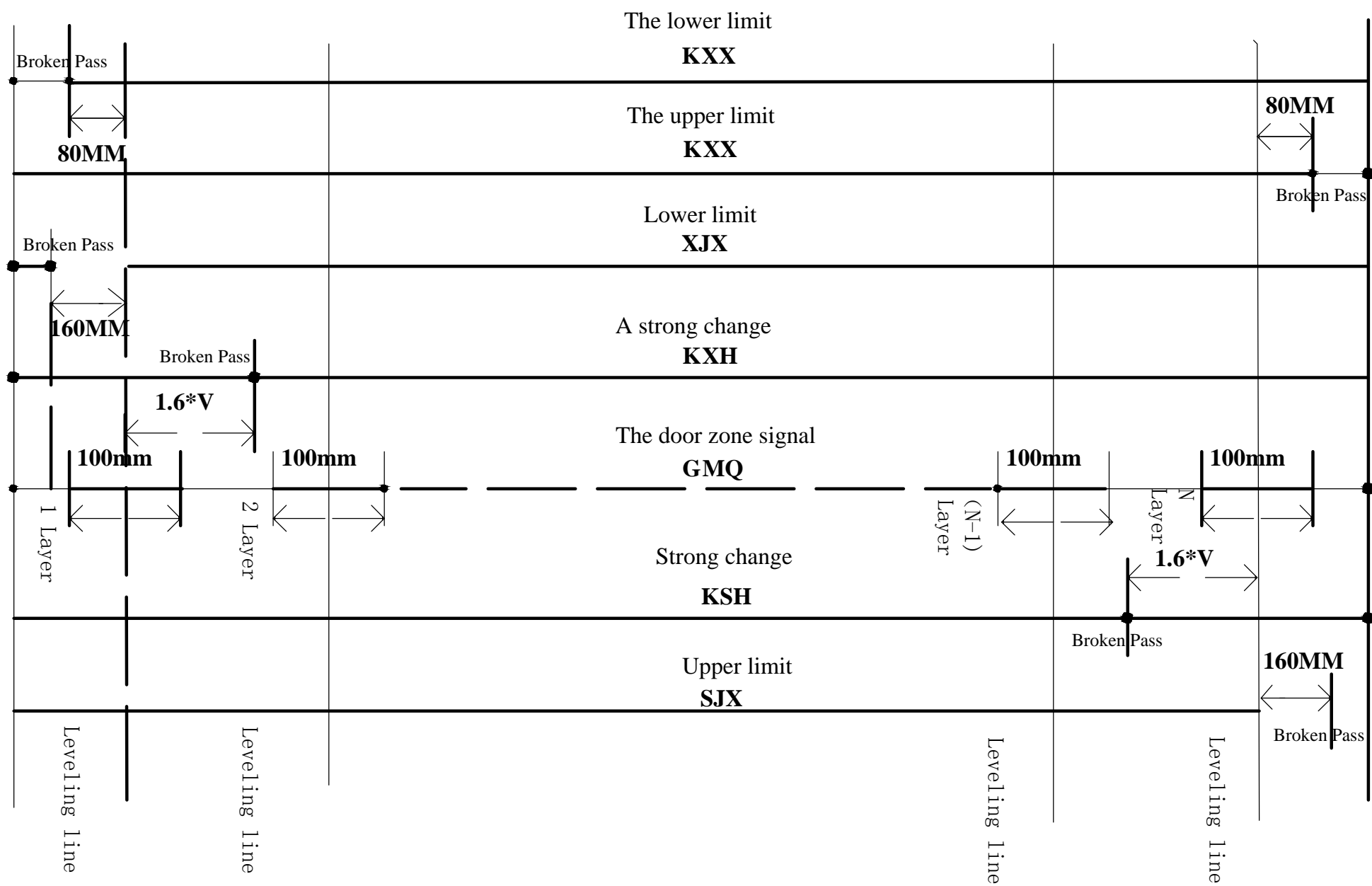

Leveling sensor line

Red, yellow --> +24V
 Blue --> COM
 white --> Output

Level sensor installation sequence:

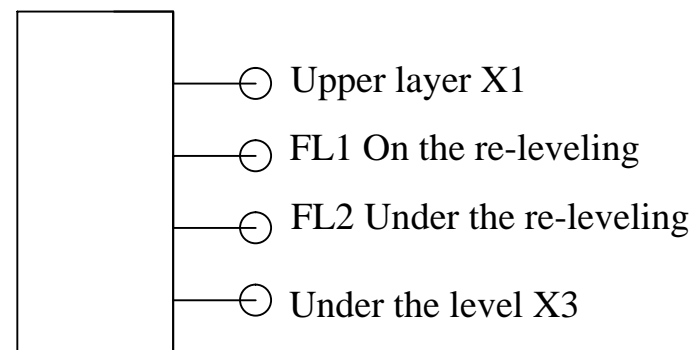

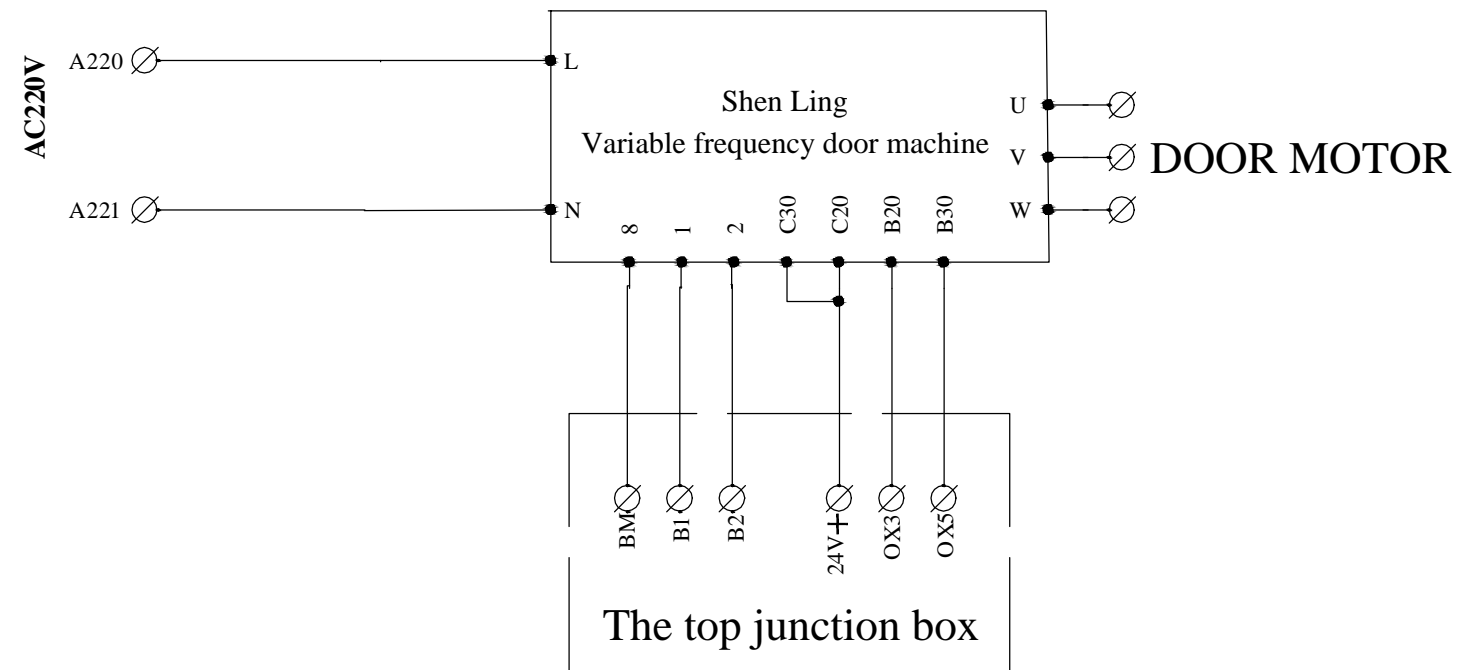

Door machine circuit	BSJ
	14/20

Hoistway cables ROI

Plug pin number	The drawing code	The cable	Function description
FBM1-1	L5	1	220V Light
FBM1-2	N	2	
FBM1-7	K35	3	Safety circuit
FBM1-10	K36	4	
FBM1-6	A12A	5	
FBM1-5	A116	6	Hall door lock loop
FBX1-7	JM	7	
FBX1-8	118	8	
FBM1-11		9	
FBM1-9		10	The upper limit
FBS1-11	X12	11	
FBS1-10	X14	12	Strong reducing 1
FBS1-7	X15	13	A strong reducing 1
FBS1-8	X13	14	The lower limit
FBS1-12	24V+	15	The utility line
FBS1-1	E5	16	Walkie-talkie
FBS1-2	E8	17	
FBS1-3	E2	18	
FBS1-4	E3	19	
FBM1-3	PE	20	Ground wire
FBM1-8	A11G	21	Pit stop button

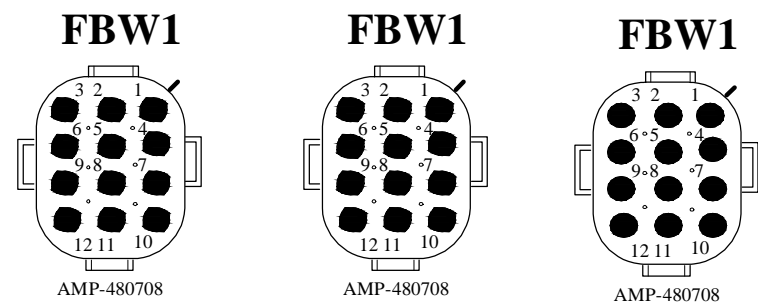

skills requirement:

1. Circular on both ends of the cable must be a round cable code identification is permanent
2. Both ends of the cable must be set round with corresponding number tube, and tube ID number is permanent
3. Name of branch line to the corresponding line posted
4. Control cabinet strpping 3000mm, branch line strpping 100mm
5. The pit and the blu ray system

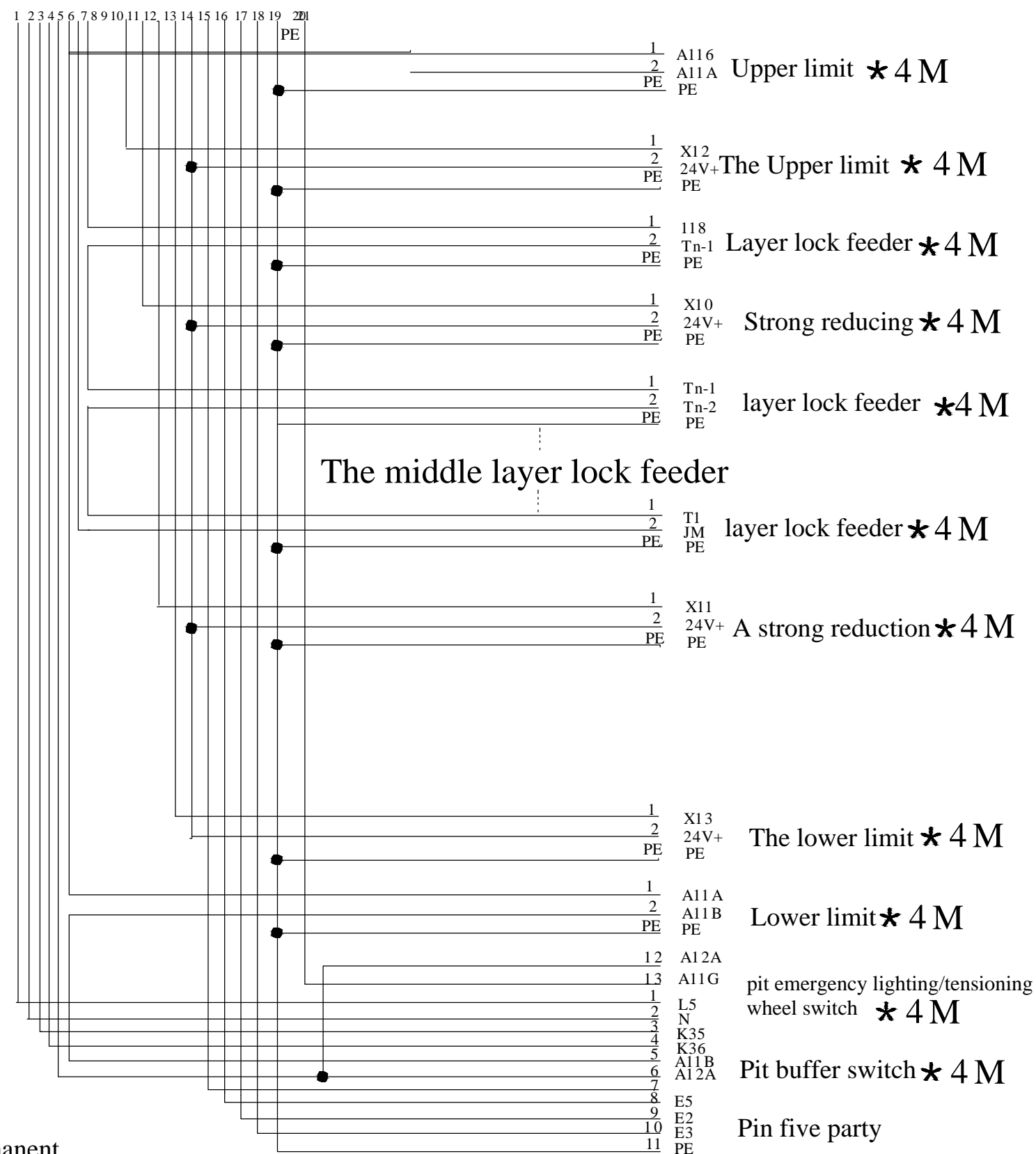

Well safely cable plug	BSJ
	15/20

24V+

MOD+

MOD-

COM

The N layer called fight

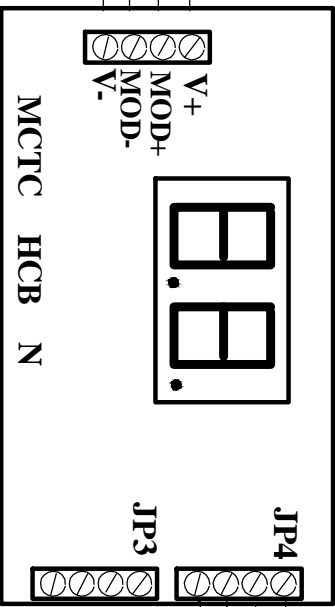

N layer down call button

The N-1 layer called fight

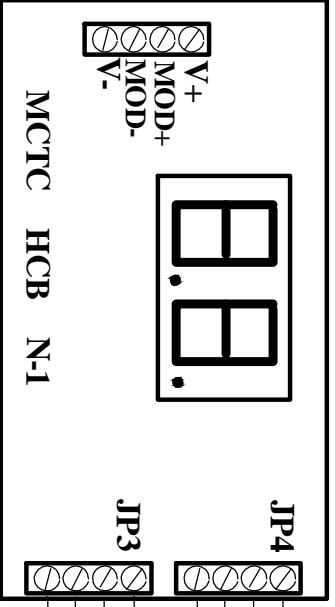

N-1 layer down call button

The 2 layer is called as

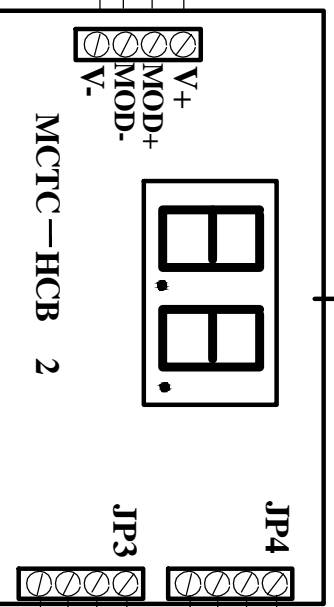

2 layer call button
2 layer down call button

The 1 layer is called as

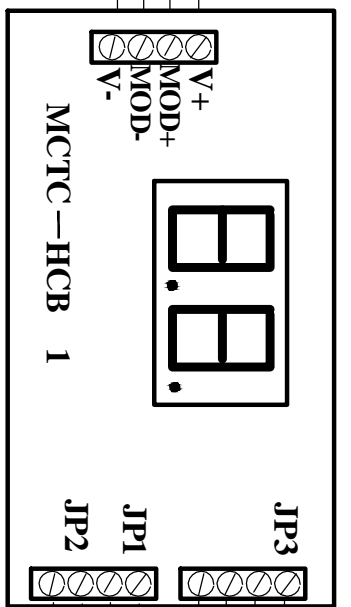

1 layer call button
A lock staircase
Firecontrol

Outbound communication circuit	BSJ
	16/20

R S T PE
Power board room
L N PE

RV 3*1.5MM
RV 1*2.5MM (Olivine)
RV 1*6MM (Olivine)
RV 3*6MM (Yellow, Green, Red)

Eleavator control cadinet

RV2*1MM

BK1 BK2
 brake

RV1*6MM
RV1*6MM

U V W PE
 The motor

RV 1*0.25MM

Five core shielded cable

Rotary
Code

RV 1*2.5MM
RV 2*1MM

A11C A115 PE
 Speed governor

RV 1*2.5MM
RV 2*1MM

A115 A114 PE
 Upstream overspeed
protector

RV 1*2.5MM
RV 2*1MM

A111(D111) A114 PE
 Hand winding device

Room layout diagram	BSJ
17/20	



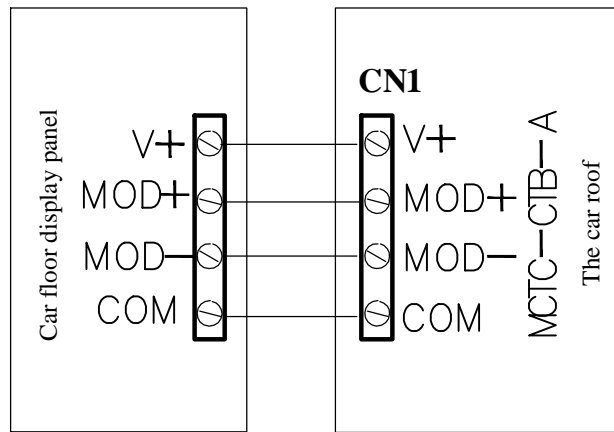
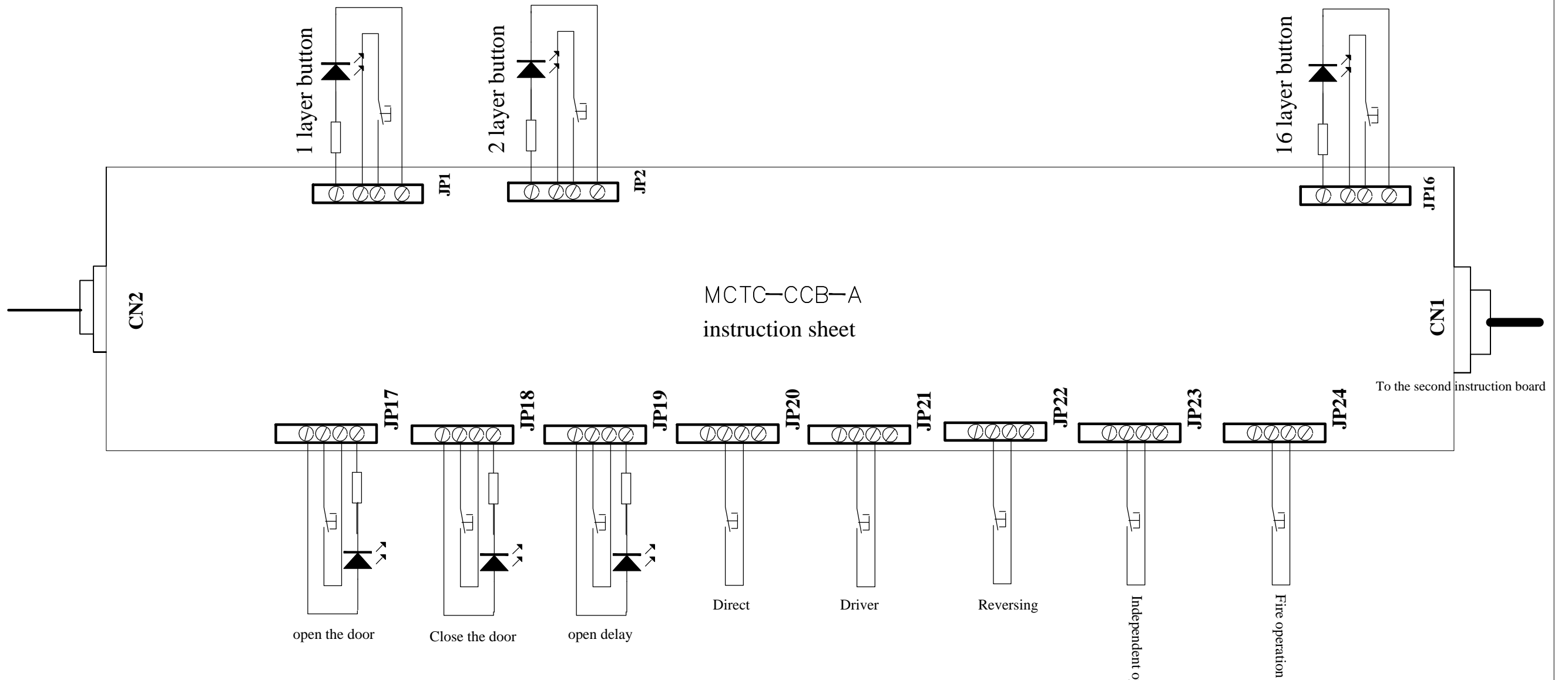



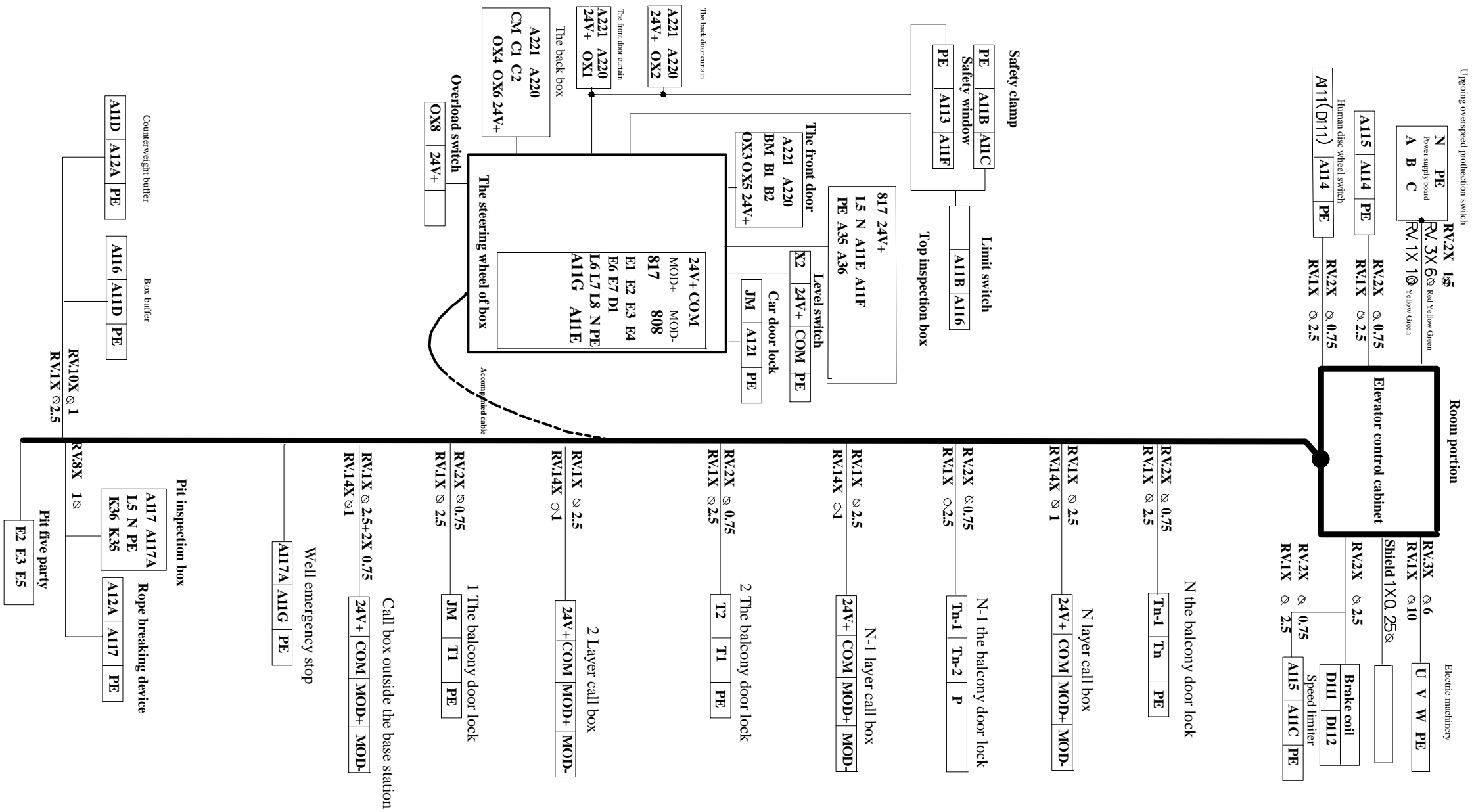

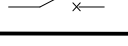
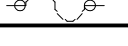

To the car roof CN7 (MCTC-CTB-B)

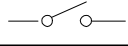
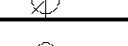

Internal communication line	BSJ
	18/20

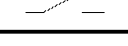
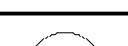

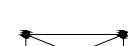
code and symbols expaination

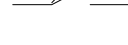
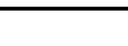
code in diagram explanation				motor & invertor expanlaiton		symbols explanation	
AC	C.O.P push buttons	JMS	reply of door lock	KDH	counter-weight buffer smith	inverter	 normal close contact
AGM	door close button	GMQ	sensor switch of door area	KJH	buffer smith of cabin	inverter	 normal open contact
AKM	door open button	CBZ	contactor of internal contacting brake	KMZ	fulload switch	TD3100	 fuse
AS	up drection button on C.O.P	CST	contactor of lock lift	KAC	safety mindow switch		 traveling cable
AXS	slow up button of cabin	JJT	contactor of emergency stop	KGM	sensor or couch tablet switch	mother board	 diade
ADS	slow up button of car top	KAQ	safety gear switch	KXS	speed govenor switch	HY-3000SP	 resistance
AFS	slow up button of Machine room	KKM	light switch of pit	KCZ	dverload switch	communation board of H.O.P	 Fan
AX	down drection button of C.O.P	KDM	light switch on ceiling	KST	lock uft switch	HY-IN	 sensor switch
AXX	slow up button of cabin	KXM	light switch on cabin	KZS	stralght drive switch	communation board of H.O.P	 push button switch
ADX	slow up button of car top	KFS	fan switch	QFM	buzzer	HY-OUT	 buzzer
AFX	slow up button of Machine room	KFT	emergency stop switch of Machine	Q1~Q n	air switch		 ternimal
BZ	Brakes coil	KKT	emergency stop switch of pit	RZ	brake reslstor		 termial steip ternimal
BDY	power supply device	KXT	emergency stop switch of cabin	PG	rotary encoder		 Indicate led
CZC	operation output contactor	KDT	emergency stop switch of ceiling	SJX	up derction emergency terminal		 loop
CZD	overload led	KXJ	inspection switch of cabin	XGM	door close umit		 connecting to the earth
CDY	power supply input contactor	KDJ	inspection switch on ceiling	XKM	door open umit		 conact point
DY	Traction Machine	KFJ	inspection switch of Machine	XJX	down derction emergency terminal		 push button
DZZ	Station clock	DDM	light led of ceiling	ZDJ	socket in the ceiling		 push button
EAC	C.O.P led	DKM	light led of the pit	ZFJ	socket in the machineroom		 rotary encoder
ES	up direction led	DXM	light led of cabin	ZKJ	socket in the pit		 rotary encoder
ESH	up direction led of C.O.P	KJM	door lock contact paint of cabin door	EPS	emergency power supply		 motor
EX	down direction led	KSJ	driver	CBZ1	internal contracting brake contractor 2		 motor
EXH	down direction led of C.O.P	KTM1/KTMn	gate interlock	TSMQ	magnetic leveling switch of roomless uft		 loop of internal contracting brake
F1~FN	fuse protection reply	KZS	Tension sheave switch	HMQ	leveling indicate led of contraller		 loop of internal contracting brake
FS	fan of cabin	KXF	flreman switch				 Arrlvai gong
JXX	phase protection reply	KXX	learning switch				 traveling switch
JKM	door open contactor	KSX	up umit switch				 traveling switch
JGM	door colse contactor	KSH	up slow umit switch				
JJT1	asslst reply of emergency stop	KXX	down umit switch				
JST	asslst reply of lock lift	KXH	down slow umit switch				

BSJ

20/20

Electrical symbol description